

# ***Operating Instructions***

---

## ***Ring saw HRH500 ★ ★ ★***

*Index 000*

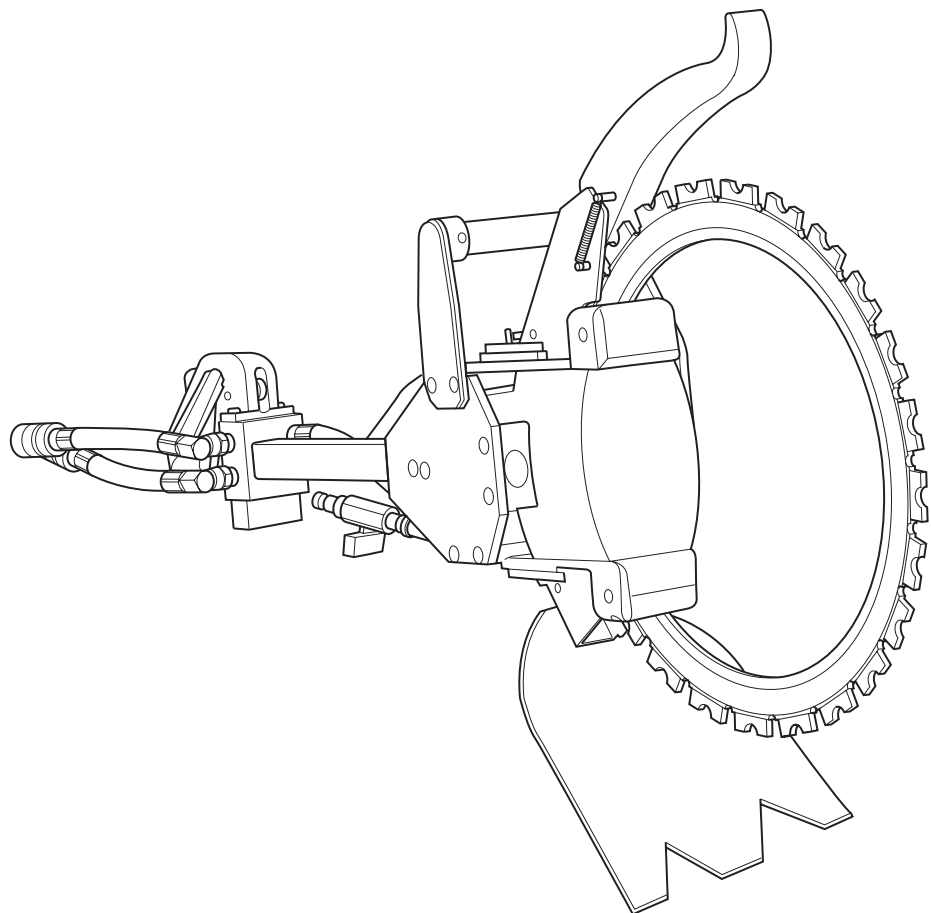

## **Congratulations!**

You have decided to purchase a tried and tested TYROLIT Hydrostress appliance and have thus acquired a highly sophisticated and reliable state-of-the-art device. Only genuine TYROLIT Hydrostress replacement parts can guarantee quality and interchangeability. If maintenance work is neglected or carried out inexpertly we will be unable to honour our warranty obligations. Any repair work must only be carried out by trained personnel.

In order to keep your TYROLIT Hydrostress appliance in perfect condition our after-sales service are always at your disposal and pleased to help.

We hope that working with your TYROLIT appliance will be a satisfying and trouble free experience.

TYROLIT Hydrostress

Copyright © TYROLIT Hydrostress

TYROLIT Hydrostress AG  
Witzbergstrasse 18  
CH-8330 Pfäffikon  
Switzerland  
Tel. 0041 (0) 44 952 18 18  
Fax 0041 (0) 44 952 18 00

# 1 About these instructions

These instructions are part of the appliance. They describe the safe and proper use in all phases of operation.

- Before use read the instructions carefully, especially the information on safety.
- Keep the instructions somewhere safe during the life of the appliance.
- Make these instructions available to the operator and service engineer at all times.
- Pass on these instructions to future owners or users of the appliance.
- Always keep these instructions up-to-date by including the received manufacture's up-dates.

## 1.1 Danger symbols in these instructions



### **DANGER**

Warning of danger where failure to comply could lead to death or serious injury.



### **WARNING**

Warning of danger where failure to comply could lead to injury or damage to property.



Information for the optimum use of appliance. Failure to take note of this information may mean that the performances shown in the technical data can not be guaranteed.

## 2 Safety information

### 2.1 Pay attention to the safety information

One is only permitted to work with the appliance when the safety information has been read and understood.

The appliance has been inspected before being shipped and is delivered in perfect condition. TYROLIT Hydrostress accepts no liability for any damage arising due to disregarding these instructions. This applies in particular to the following damage:

- Damage caused by improper use and operator error
- Damage resulting from disregard of the safety relevant information in these instructions or the warning labels on the appliance
- Damage resulting from unsatisfactory maintenance work

### 2.2 Correct application

The ring saw is to be used by trained personnel for cutting concrete, brickwork and masonry. The appliance is intended to be connected to a drive unit and must be connected and the drive engaged in accordance with the drive unit operating instructions.

Adhering to these instructions constitutes proper use of the appliance.

#### Misuse:

- Working without protective equipment or with inadequate protective equipment
- Cutting other materials
- Removal of protective devices
- Cutting in areas with danger of explosion
- Cutting loose parts
- Incorrect or absence of waste water disposal (saw sludge)

### 2.3 Target groups and responsibility

#### 2.3.1 Authorised personnel

Working on or with machines or systems from TYROLIT Hydrostress may only be undertaken by authorised personnel. Personnel are considered to be authorised if they meet the necessary training and know-how requirements and they have been assigned a precise functional role.

#### 2.3.2 Manufacturer

As manufacturer of the product, which is supplied by TYROLIT Hydrostress accept:

- TYROLIT Hydrostress
- a TYROLIT Hydrostress specifically named company

Within the context of an integrated quality assurance and safety control system, the manufacturer is entitled to request from the operator information about the products.

#### 2.3.3 Operator

The operator named by TYROLIT Hydrostress is the primary, legal entity responsible for the correct use of the product and for the training and assignment of the authorised personnel. The operating company sets out the mandatory skills and level of training of the authorised personnel for the company.

#### Personnel qualifications

- A technically trained person in a management position
- Has relevant experience in personnel management and danger assessment
- Has read and understood the safety instructions

### 2.3.4 Operator (user)

As a user TYROLIT Hydrostress designates a person who independently performs the following work:

- Setting up of machines and systems from TYROLIT Hydrostress within the scope of intended application
- Independent execution and supervision of work
- Location of faults and instigation of fault rectification or independent fault rectification
- Maintenance
- Verify the correct functioning of the safety devices

#### Personnel qualifications

- Completed training as a concrete cutting specialist or relevant occupational experience
- Introduction (basic training) in the operation of the appliance by a service technician

### 2.3.5 Service technician

As a service technician TYROLIT Hydrostress designates a person who independently performs the following work:

- Installation of machines and systems from TYROLIT Hydrostress
- Makes adjustments to machines and systems for which special access rights are required
- Complex service and maintenance work

#### Personnel qualifications

- Specialist professional training (mechanical / electro technical)
- Product specific training from TYROLIT Hydrostress

## 2.4 Organisational measures

### 2.4.1 Product monitoring obligation

The appliance must only be operated in a defect free and undamaged condition. Operating personnel must notify immediately changes in operational behaviour or safety-related components to a responsible person or the manufacturer.

The maintenance intervals must be adhered to. Faults affecting safety must be rectified immediately.

### 2.4.2 Location of these instructions

A copy of the instructions must be available to staff at all times at the location where the apparatus is used.

### 2.4.3 Workplace

- ▶ Create sufficient free space to enable safe working.
- ▶ Provide sufficient workplace illumination.
- ▶ Cordon off danger area visibly so that during sawing operations no person can enter the danger area.

## 2.5 Protective devices and labels on the appliance

### 2.5.1 Protective devices

Protective devices must only be removed when the appliance is turned off, disconnected from the mains and at a standstill. Safety components, in particular, may only be removed and refitted by authorised personnel.

Before switching the appliance back on again, the safety elements must be checked to ensure correct operation.

### 2.5.2 Labels on the appliance

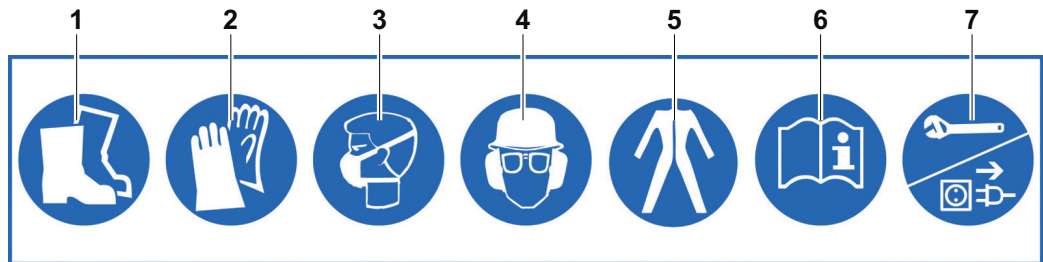







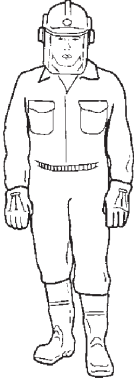

- |   |  |   |  |
|---|--|---|--|
| 1 | Wear safety shoes                                    | 5 | Wear protective clothing   |
| 2 | Wear protective gloves                               | 6 | Read the instructions  |
| 3 | Wear a breathing mask                                | 7 | Disconnect from the mains supply before working on the appliance |
| 4 | Wear hard hat, eye protection and hearing protection |   |  |

## 2.6 Replacement parts and modifications

Only original spare parts from TYROLIT Hydrostress must be used. Otherwise damage may be caused to the appliance or to other property and persons.

No additions or modifications may be carried out to the appliance without the written agreement of TYROLIT Hydrostress.

## 2.7 Personal protective clothing

Personal protective clothing			
			
			
			

## 2.8 Residual risks

On the basis of residual risks, which are described in the following chapters, there is danger of serious injuries.

### 2.8.1 Sharp edges

On coming in to contact with the tool there is a danger of serious cut injuries.

- ▶ Do not touch tool when in operation.
- ▶ Only touch a stationary tool when wearing gloves.

### 2.8.2 Flying diamond segments

- ▶ Each time before use ensure that the blade guard is correctly fitted and undamaged.
- ▶ Only begin sawing when no other person is in the danger area.
- ▶ Ensure that the safe distance to the ring saw of 15 m is maintained.
- ▶ Change the cutting ring when diamond segments break off.

### 2.8.3 Recoil

Due to incorrectly fitting the cutting ring or cutting unspecified materials the ring saw can suddenly recoil seriously injuring the operator.

- ▶ Only cut materials that are permitted within the scope of intended application.
- ▶ Do not place the cutting ring above the centre at a work piece corner.

### 2.8.4 Unintentional start up

- ▶ Before operating ensure:
  - The switch handle with safety lock functions correctly.
  - There is no other person in the danger area.

### 2.8.5 Uncontrolled movements and vibrations

- ▶ Never connect or disconnect hoses while the drive unit is running.
  - ▶ When the ring saw is switched on always hold the handle firmly with both hands. Thumbs and fingers must be closed around the handles.
  - ▶ Keep the handle clean.
- A loose cutting ring can cause uncontrolled vibration of the ring saw.
- ▶ Ensure that the smooth drive rolls are fitted correctly.

### **2.8.6 Vibrations**

Vibrations can cause circulatory problems or nerve damage.

- ▶ On signs of symptoms seek medical help.

### **2.8.7 Catching and entanglement**

Items of clothing or long hair can get caught up in rotating cutting rings.

- ▶ Only operate when wearing appropriate protective clothing.
- ▶ Do not operate when wearing loose hanging items of clothing.
- ▶ If hair is long wear a hairnet.

### **2.8.8 Pressure connections**

Hydraulic oil can be released at high pressure.

If the hoses cannot be connected or only connected with difficulty, they are under pressure.

- ▶ Check hydraulic connections regularly for damage and if required have changed by an authorised person.
- ▶ Never connect or disconnect hoses while the drive unit is running.
- ▶ Never apply force to connect couplings.
- ▶ Depressurise the hoses by means of the pressure relief device.

### **2.8.9 Flying particles**

Flying particles can cause injury to eyes.

- ▶ Wear protective glasses or visor.
- ▶ Secure danger area professionally.

### **2.8.10 Falling parts**

Falling parts can cause serious head and foot injuries.

- ▶ Wear safety helmet and protective shoes with steel toecaps.
- ▶ Secure removed pieces of concrete against falling.
- ▶ Secure against parts or saw slurry falling to the front, below and to the rear of the sawing area: Persons must not be injured and equipment not damaged.

### **2.8.11 Noise**

Noise can cause hearing damage.

- ▶ Wear hearing protection.

### **2.8.12 Harmful vapours and aerosols**

Inhaling harmful vapours and aerosols can cause breathing problems.

Breathing in the water fog that is created is a health hazard.

- ▶ Wear a breathing mask.
- ▶ In enclosed spaces ensure that there is adequate ventilation.

### **2.8.13 Hydraulic oil**

Contact with hydraulic oil can cause allergic reactions.

- ▶ Wear protective gloves.
- ▶ On contact with hydraulic oil the affected skin areas must be washed immediately with plenty of water.

On connecting and disconnecting the hoses there is the danger of an uncontrolled hydraulic oil leak.

- ▶ Never connect or disconnect hoses while the drive unit is running.



### **2.8.14 Electrical energy**

A defective electric device (e.g. drive unit) can result in an electric shock.

- ▶ Before operating and regularly during long operating periods check the electric device for damage.
- ▶ Defective parts, as for example cable and plug, should be replaced by electrically trained personnel.
- ▶ Disconnect the mains plug before working on electrical devices.

### **2.8.15 Danger of slipping**

- ▶ Do not operate on uneven surfaces.
- ▶ Wear safety shoes with non-slip soles.

The sludge resulting from cutting is very slippery.

- ▶ Remove the sludge or ensure that people can not slip on it.

### **2.8.16 Unfit to work**

- ▶ Do not operate when under the influence of alcohol, drugs or medication.
- ▶ Do not operate when overtired.

### **2.8.17 Danger of the ring saw restarting in the event of an accident**

- ▶ Ensure that the ring saw (e.g. by means of the drive unit emergency STOP) can be brought rapidly to a halt.

### **2.8.18 Reduced blade quality**

- ▶ Do not use damaged cutting rings.
- ▶ Check cutting ring for damage before fitting.
- ▶ Do not fit new diamond segments to saw blades.

## **2.9 Danger of damage to property**

### **2.9.1 Sideways cutting**

Cutting with the side of the blade can damage the cutting ring.

- ▶ Do not cut sideways.

### **2.9.2 Deficient water cooling**

The cutting ring can be damaged when cutting with insufficient water cooling.

- ▶ Do not operate ring saw without water cooling.

### **2.9.2 Excessive pressure**

The drive can be damaged by excessive pressure.

- ▶ Do not operate ring saw at a pressure higher than specified.
- ▶ If necessary install pressure reducing valve or a flow divider.

### **2.9.3 Frost damage**

- ▶ On termination of work or before long shut downs drain the water system and blow out.

### 3 Description

#### 3.1 Ring saw

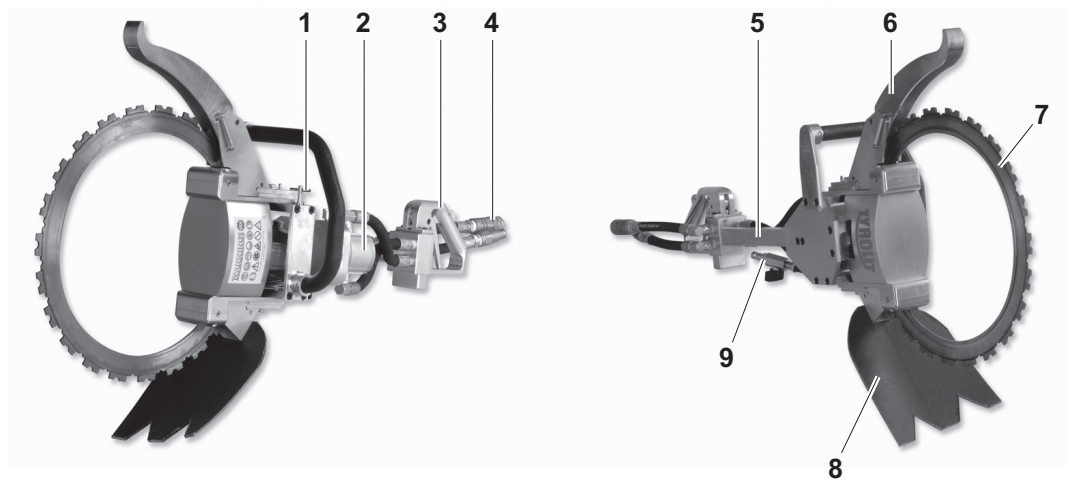

- |                             |                           |
|-----------------------------|---------------------------|
| 1 Roller pre-tension device | 5 Frame                   |
| 2 Hydraulic motor           | 6 Blade guard             |
| 3 Operating handle          | 7 Cutting ring            |
| 4 Hydraulic coupling        | 8 Splash protection flaps |
|                             | 9 Water connection        |

#### 3.2 Accessories

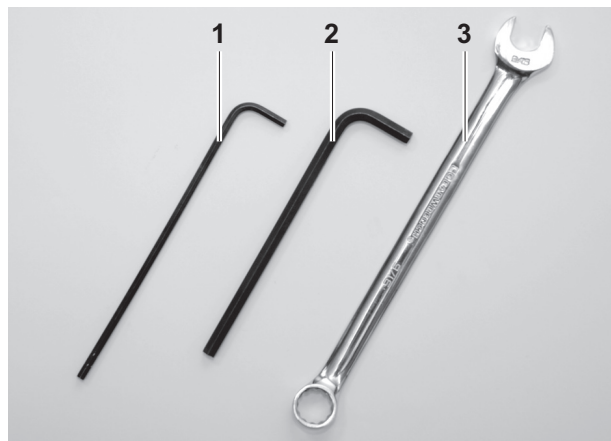

- |                                 |
|---------------------------------|
| 1 Allen key WAF 5/32"           |
| 2 Allen key WAF 1/4"            |
| 3 Combination spanner WAF 9/16" |

## 4 Preparatory operations

The work is prepared in the following manner:

1. Clarify the fundamental conditions:
  - Position of pipes and cables in walls, floors and ceilings
  - Cooling water drainage (danger of electric shock and water damage)
2. Securing the site.
3. Secure out-cuts from wall, ceilings or floors (e.g. crane or supports). Consider the weight of concrete (1m<sup>3</sup> weighs 2400 to 2700kg). Decide on the position and sequence of cuts.
4. Visually inspect the ring saw.

### 4.1 Position and sequence of cuts

#### 4.1.1 Decide on position

- ▶ Obtain information on sawing concrete or sawing brickwork:
  - Where does the reinforcement run?
  - Is the concrete heavily or lightly reinforced?
- ▶ Cuts in concrete to be as near as possible at right angles

#### 4.1.2 Define the sequence of cuts



An incorrect sequence of cuts can lead to the cutting ring jamming.

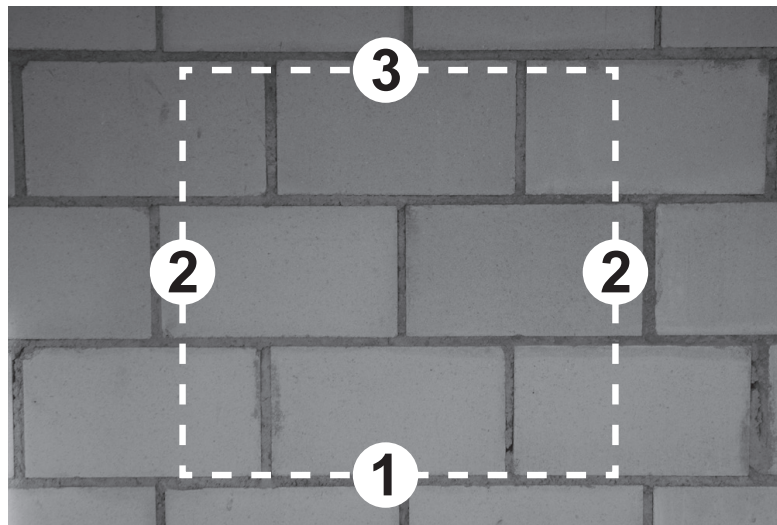

- ▶ Define the sequence of cuts (e.g., for a window cut-out carry out the bottom cut first, then the side cuts and finally the top cut).

## 5 Assembly / disassembly

### 5.1 Cutting ring assembly

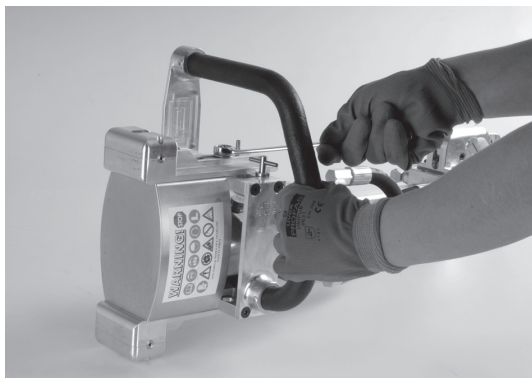

1. Undo upper bolts.

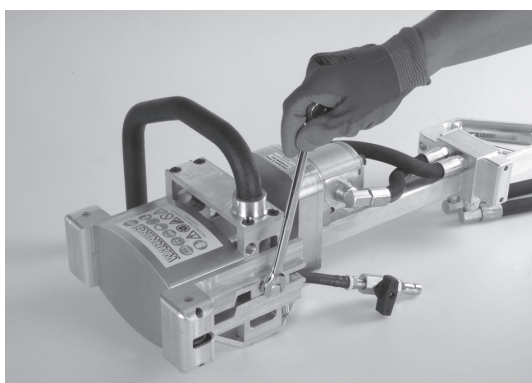

2. Undo lower bolts.

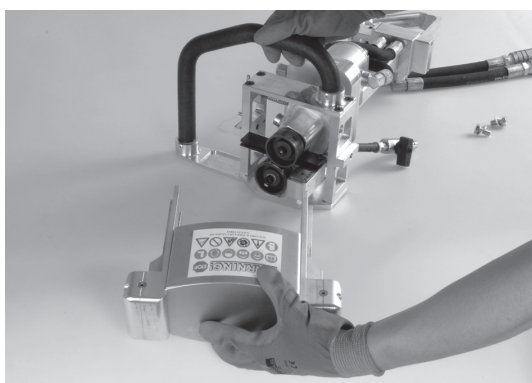

3. Remove cover.

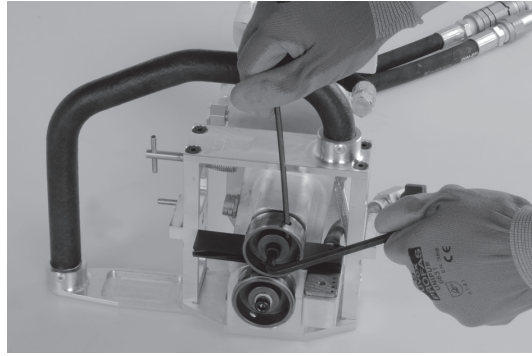

4. Undo securing bolts of smooth drive roller.

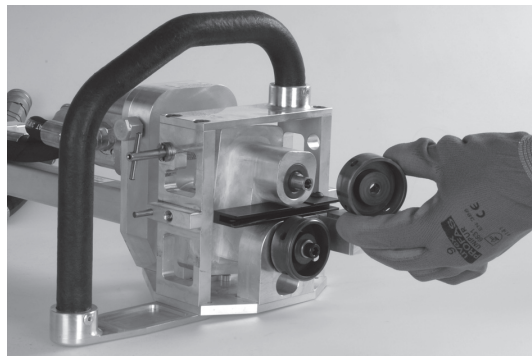

5. Remove smooth drive roller.



6. Thoroughly clean cutting ring.

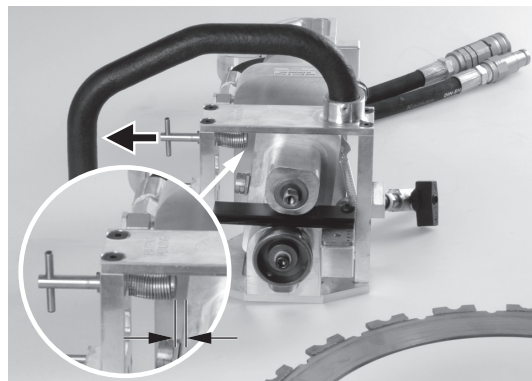

7. Withdraw and lock roller pre-tension device.

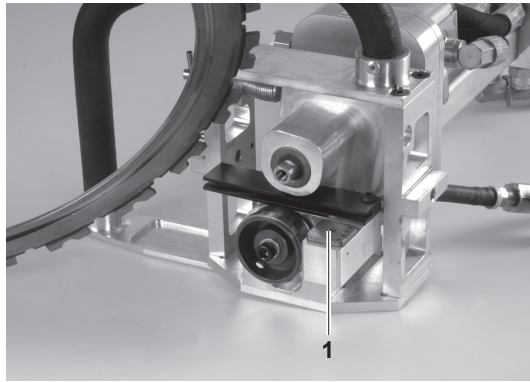

**8.** Replace slide plate (1).

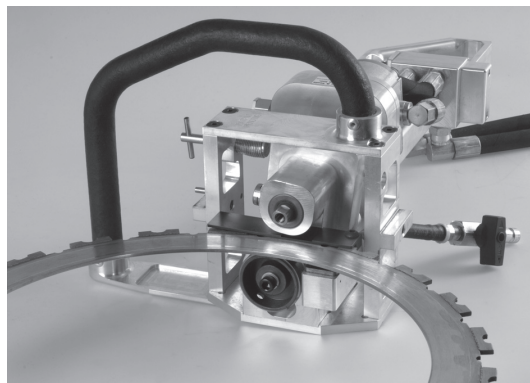

**9.** Place cutting ring on profiled drive roller. Ensure that the cutting ring groove lies on the profiled drive roller recess.

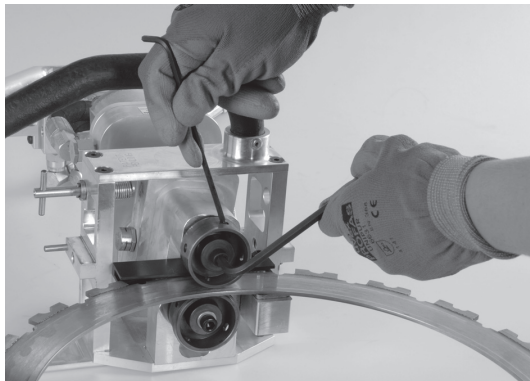

**10.** Tighten smooth drive roller bolts.



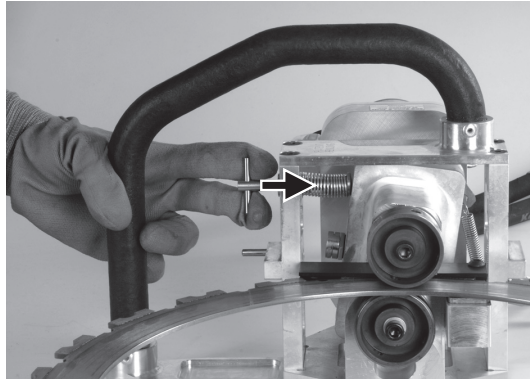

**11.** Slacken roller pre-tension device.

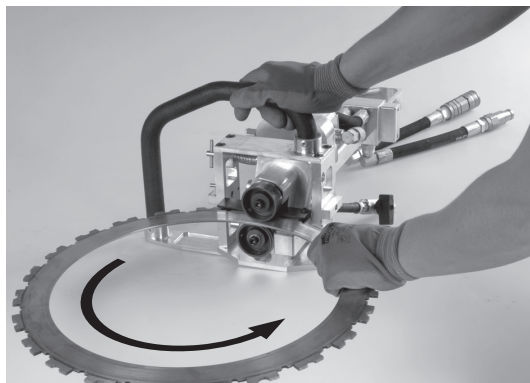

**12.** Check the cutting ring for free movement.

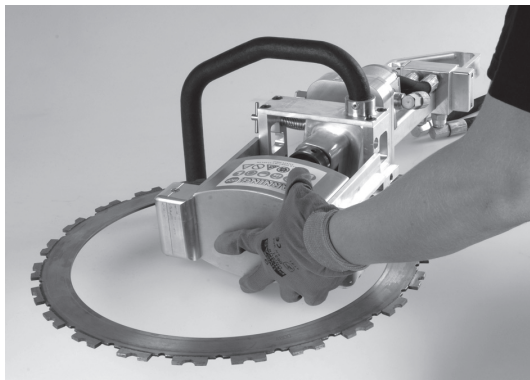

**13.** Replace cover but do not yet tighten bolts.

## 5.2 Fit safety devices

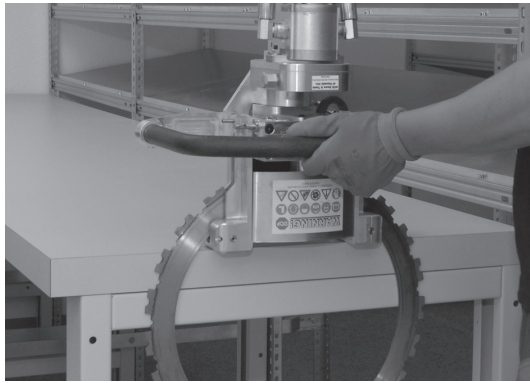

1. Place casing on table edge.

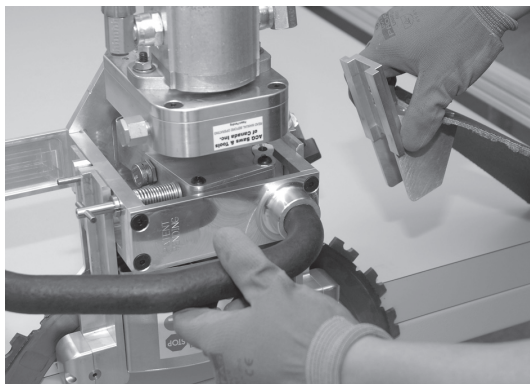

2. Bolt on splash protection flaps loosely.

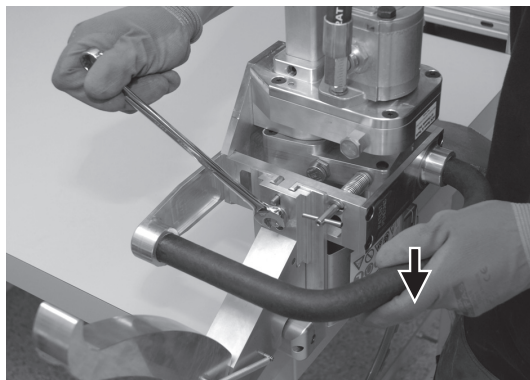

3. Press the casing down on to the base plate and keep pressed.  
4. Tighten bolts of blade guard and splash protection flaps.



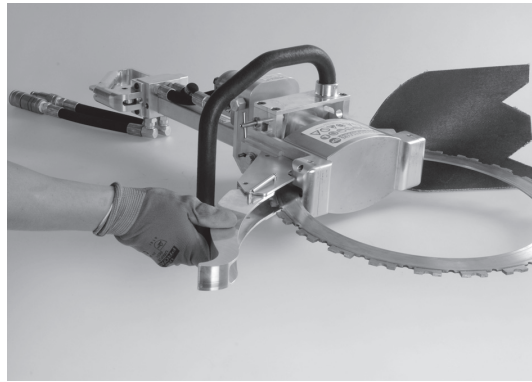

5. Rotate blade guard over the cutting ring.

### 5.3 Attaching hose connectors

#### 5.3.1 Attachment preparations

- ▶ Ensure cleanliness of connections, ring saw and service connections.
- ▶ Check hoses and couplings for damage and oil leaks.

#### 5.3.2 Connect hydraulic hoses

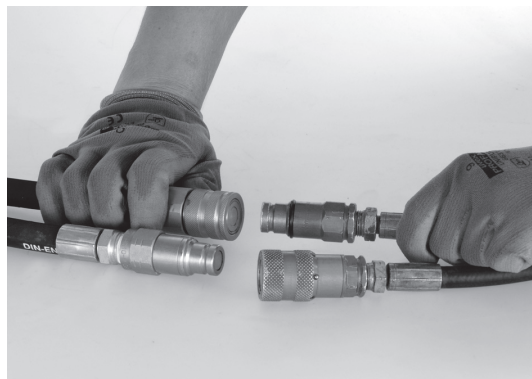

▶ Connect hydraulic hoses.

#### 5.3.3 Connect water hose

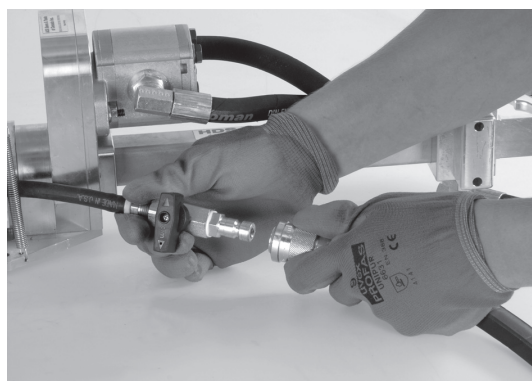

▶ Connect water hoses.

## 6 Operation

### 6.1 Operating procedure

1. Start the drive unit.
2. Open drive unit water valve and check water delivery to ring saw.
3. Set operating pressure.
4. Hold ring saw firmly with both hands.

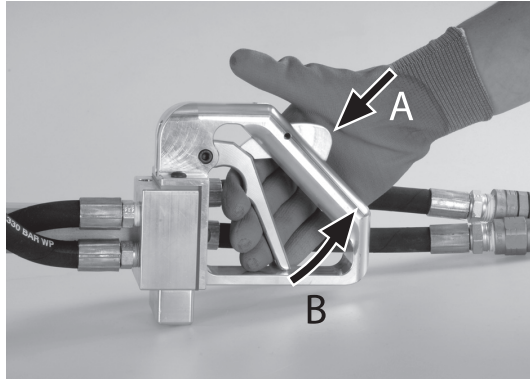

5. Press on safety handle (A) and operate hand start lever (B).
6. Check direction of cutting saw rotation.



#### WARNING

Danger of injury due to sudden recoil of ring saw.

- ▶ Do not place the cutting ring above the centre at a work piece corner.

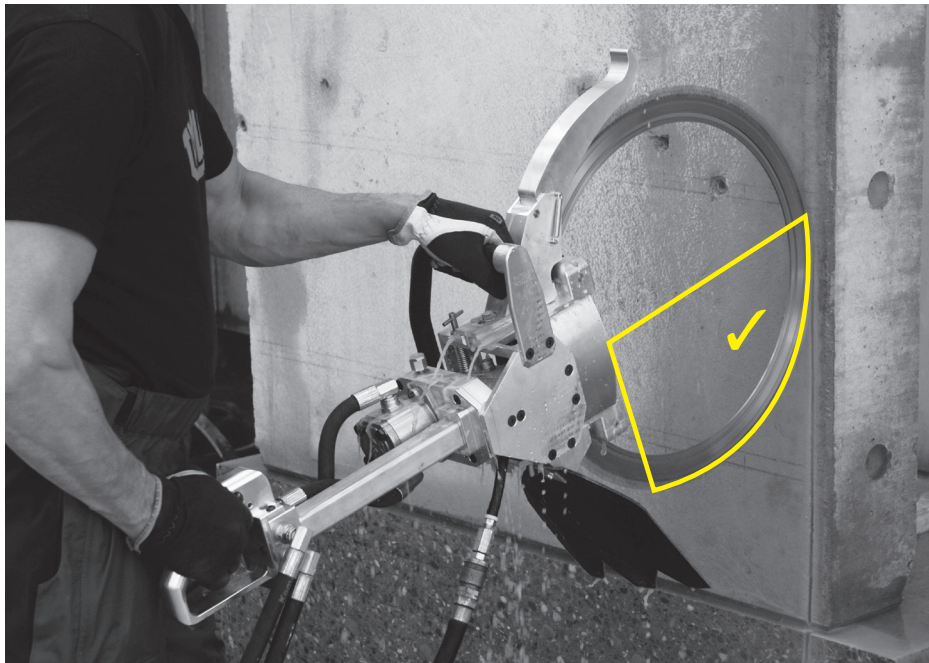

7. Position the cutting ring below the centre position.



It is more economical to achieve the total required depth of cut in a number of steps.

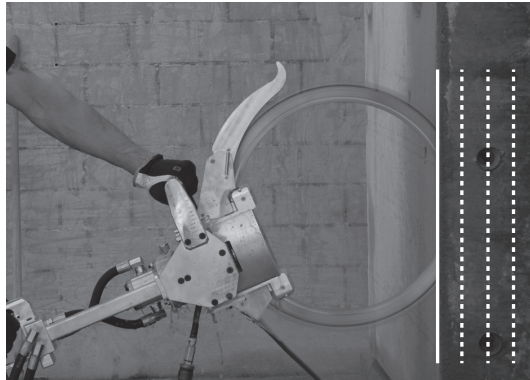

8. Cutting:
  - For optimum guidance first of all make a cut from 50 to 70mm deep.
  - Divide the total depth of cut into a number of steps.

## 6.2 Terminating the work

1. Close off and disconnect the water feed.
2. Blow out water from all lines.
3. Withdraw drive unit mains plug.
4. Disconnect hydraulic hoses.
5. Clean ring saw with water.

## 7 Maintenance

Maintenance and servicing table		Before starting work each time	At end of work	Weekly	Annually	When faults occur	After damage
Hydraulic system	▶ Check hydraulic hoses and connectors (damage, leaks, cleanliness).	X	X			X	X
Water supply	▶ Check water supply (damage, leaks, cleanliness).	X	X			X	X
	▶ Blow out water (frost hazard).		X				
Rollers	▶ Check rollers for wear.	X				X	
Motor	▶ Clean and thoroughly grease motor valves.	X					
Blade guard	▶ Check blade guard.	X					
Cutting ring	▶ Check the cutting ring for wear.	X	X				
Guide plate	▶ Check guide plate alignment.	X					
Major service	▶ To be performed by TYROLIT Hydrostress AG or an authorised workshop.				X		

### 7.1 Change rollers

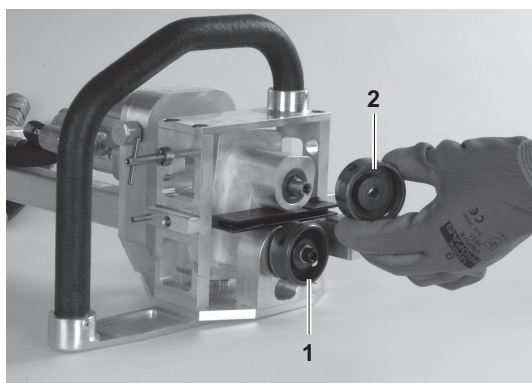

- ▶ Change drive roller (profiled) (1) and drive roller (smooth) (2).

## 8 Faults

Faults		
Fault	Possible cause	Solution
Ring saw does not start	Drive unit switched off	▶ Switch on drive unit.
	Emergency STOP on drive unit pressed	▶ Re-set emergency STOP.
Cutting ring does not rotate	Cutting ring not located correctly on the profiled drive roller	▶ Mount the cutting ring correctly.
	Incorrect hose connection	▶ Check hydraulic system.
	Hydraulic motor fault	
	Oil delivery not connected properly	
	Main drive unit motor not switched on	▶ Switch on main motor.
	Drive rollers dirty	▶ Clean drive rollers.
	Roller pre-tension device not engaged	▶ Check roller pre-tension device.
Cutting ring revolves too slowly	Drive rollers worn	▶ Change drive rollers.
	Roller bearing defective	▶ Change roller bearing.
	Inadequate oil flow and pressure	▶ Check drive unit.
	Roller pre-tension device not engaged	▶ Check roller pre-tension device.
Cutting ring disengages	Roller distance too large	▶ Check roller pre-tension device.
	Drive rollers worn	▶ Change drive rollers.
	Cutting ring damaged	▶ Change cutting ring.
	Roller pre-tension device not engaged	▶ Check roller pre-tension device.
Cutting ring twisted	Cutting ring inadequately cooled	▶ Check water cooling. ▶ Change cutting ring.
Diamond segments broken off	Cutting ring twisted	▶ Change cutting ring.
	Hard resistance in work piece	▶ Change cutting ring.
	Brazing or welding of segments not professional standard	▶ Change cutting ring.
Motor seal split	Ring saw runs backwards	▶ Check hydraulic connections and drive unit oil circuit.
	Pressure too high	▶ Check setting at drive unit. If necessary, install a pressure reducing valve and a flow divider.
	Defective seal	▶ Replace seal.
	Oil return incorrectly connected	▶ Check connector.

<b>Faults</b>		
<b>Fault</b>	<b>Possible cause</b>	<b>Solution</b>
Cutting ring twisted	Incorrect cutting ring type for the material	▶ Check cutting ring against diamond tool specification.
	Water supply inadequate	▶ Check and increase water supply.
Cutting ring slips	Drive rollers move unclean in the casing (inadequate contact between cutting ring and drive rollers)	▶ Check roller pre-tension device.
	Drive rollers worn (e.g. due to drive rubbing and inadequate water supply)	▶ Change drive rollers.
	Drive roller shoulders worn by more than 50%	▶ Change drive rollers.
	Cutting ring internal edge and guide groove worn (inadequately flushed drive area or worn drive rollers)	▶ Change drive rollers.
No water supply to cutting ring	Water line blocked	▶ Clean the water line.
	Water faucet on feed line is closed	▶ Open the water faucet.
	Insufficient water pressure	▶ Ensure minimum water pressure of 3bar.
Sparks emitted from side of cutting ring	Water supply inadequate	▶ Check and increase water supply.
Casing hot	Inadequate oil cooling	▶ Check drive unit cooler.
	Hydraulic motor fault	▶ Replace hydraulic motor
Operating handle greasy	Hydraulic component seals faulty	▶ Replace seals.

## 9 Technical data

### 9.1 Dimensions

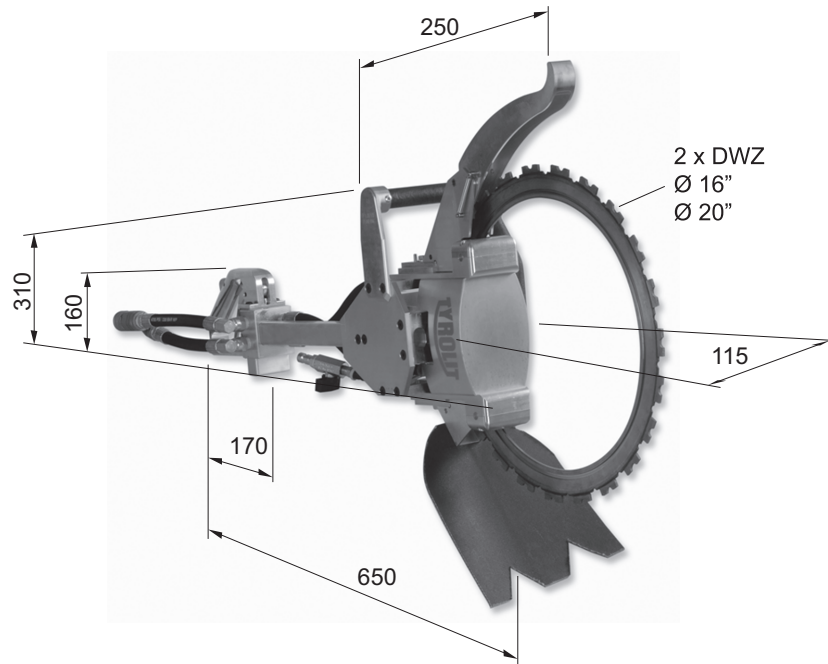

Measurements in mm

### 9.2 Ring saw

Dimensions and weight	
Parameter	Value
Weight (without cutting ring)	12.64 kg
Width	260 mm
Height	482.6 mm
Length (without cutting ring)	660 mm
Drive unit	All drive units for hydraulic application possible

Noise emission (EN ISO 3744)	
Parameter	Value
Sound pressure level $L_{pA}$	85.6 dB(A)*
Maximum value of sound pressure level $L_{pCpeak}$	105.9 dB
Acoustic power level $L_{wA}$	105.6 dB (A)*

\* Conditions for the measurement:

Cutting ring  $\varnothing$  510 mm (20") not when cutting at full load

Vibrations (EN ISO 5349)	
Parameter	Value
Vibration total value $a_{hv}$	<2.5 m/s <sup>2</sup>

### 9.3 Hydraulics

Hydraulics	
Parameter	Value
Operating pressure (max.)	172.5 bar *
Flow rate (max.)	30 l/min *
Flow rate (min.)	25 l/min

\* At flow rate > 33 l/min or pressure >175 bar flow divider with pressure limitation required.

### 9.4 Water supply

Water supply	
Parameter	Value
Working pressure	min. 3 bar max. 6 bar
Flow rate	min. 5 l/min
Temperature	max. 25 °C

### 9.5 Cutting ring and depth of cut

#### 9.5.1 Cutting ring

Cutting ring	
Parameter	Value
Diameter (max.)	510 mm (20")
Cooling	Water cooling

#### 9.5.2 Cutting depths

Cutting depths	
Diameter cutting ring	Cutting depths
510 mm (20")	407 mm
406 mm (16")	300 mm



## EC declaration of conformity

Description	Ring saw hydraulic
Type designation	HRH500 ★★★
Year of manufacture	2007

We declare under our sole responsibility that this product complies with the following directives and standards:

### Directive applied

2006/42/EG of 17th May 2006  
2000/14/EG of 8th May 2000

### Applied standards

EN 12100:2010  
EN 792-7:2001+A1:2008  
EN ISO 4413:2010  
EN ISO 13857:2008

### Manufacturer:

TYROLIT Hydrostress AG  
Witzbergstrasse 18  
CH-8330 Pfäffikon  
Switzerland

### Authorisation for the technical documentation:

TYROLIT Hydrostress AG  
Pascal Schmid  
Head of Development  
Witzbergstrasse 18  
CH-8330 Pfäffikon  
Switzerland

Pfäffikon, 2011



Pascal Schmid  
Head of Development



